

Series **STBA**

BOTTLE CAP TORQUE SENSORS

Reference Guide

MARK-10®

GENERAL

The sensor is shipped ready to use. No assembly is required.

Carefully remove the unit from its packaging and inspect for any damage.

Series STBA bottle cap torque sensors work in conjunction with the BGI force/torque indicator for instantaneous, average, and peak torque measurements. Simply plug the 15-pin connector into the external sensor connector on the indicator. Place the sample on top of the sensor and tighten the grips. Then proceed with the desired test.

Please note that all calibration data and menu selections programmed and saved during setup with the BGI are saved within the sensor. While this allows for interchangeability, each sensor must be programmed separately.

The sensor can be mounted onto a workbench if required using the four #10-32 holes on the bottom of the unit.

In order to extend the life of your torque sensor, avoid repetitive shock and impact loading.

SPECIFICATIONS

<i>Model</i>	<i>Capacity x Resolution</i>	<i>Safe Overload % of Capacity</i>
STBA10Z	10 x 0.01 ozin, 7 x 0.005 kgFmm, 7 x 0.005 Ncm	300
STBA20Z	20 x 0.02 ozin, 14 x 0.01 kgFmm, 14 x 0.01 Ncm	
STBA50Z	50 x 0.05 ozin, 36 x 0.05 kgFmm, 35 x 0.05 Ncm	
STBA12	12 x 0.01 lbin, 140 x 0.01 kgFmm, 135 x 0.01 Ncm	150
STBA50	50 x 0.05 lbin, 580 x 0.5 kgFmm, 570 x 0.5 Ncm	
STBA100	100 x 0.1 lbin, 1150 x 1 kgFmm, 1150 x 1 Ncm	

Accuracy: $\pm 0.7\%$ FS + BGI
 Operating conditions:
 Temperature: 40°F - 110°F [5°C - 45°C]
 Humidity: 96% max. (no condensation)

DIMENSIONS

in [mm]

STBA10Z – STBA50Z

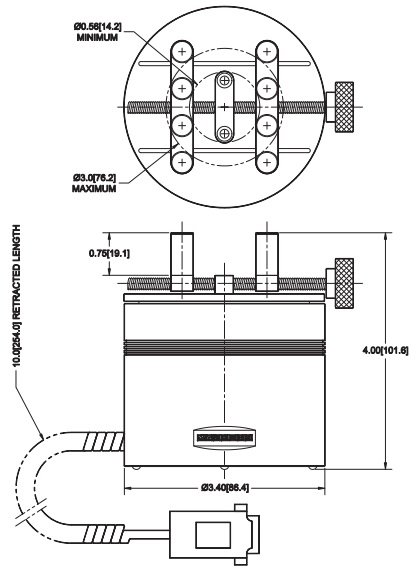

STBA12 – STBA100

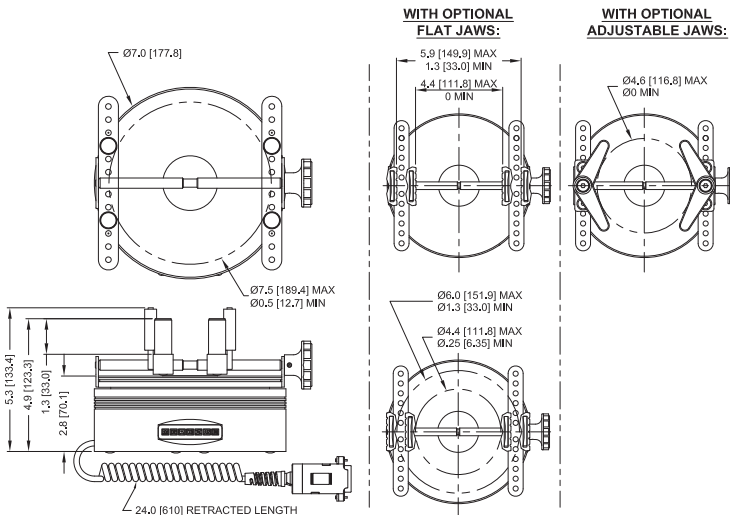

WARRANTY

Mark-10 Corporation expressly warrants to its buyer for three (3) years from the date of delivery that the goods sold are free from defects in workmanship and materials. Mark-10 Corporation will, at its option, repair or replace or refund the purchase price of goods found to be defective. This remedy shall be the buyer's sole and exclusive remedy. Any modification, abuse, exposure to corrosive environment or use other than intended will void this warranty. This warranty is in lieu of all other warranties, including implied warranties of merchantability and fitness for an intended purpose. In no event shall Mark-10 Corporation be liable for any incidental and consequential damages in connection with goods sold or any part thereof.

OTHER MARK-10 PRODUCTS

A full line of force and torque measurement products and related items, including force gauges, torque gauges, force and torque test stands, sensors, grips, software, and more.



MARK-10

We make a measurable difference in force and torque measurement

Mark-10 Corporation

11 Dixon Avenue
Copiague, NY 11726
888-MARK-TEN
Tel: 631-842-9200
Fax: 631-842-9201

Internet: www.mark-10.com.cn

